

AAA TECHNOLOGY & SPECIALTIES CO., INC.

FIG. 320
THREADED SWAY STRUT ASSEMBLY WITH FIELD WELDED EXTENSION PIECE
(ALTERNATE DESIGN)

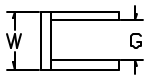
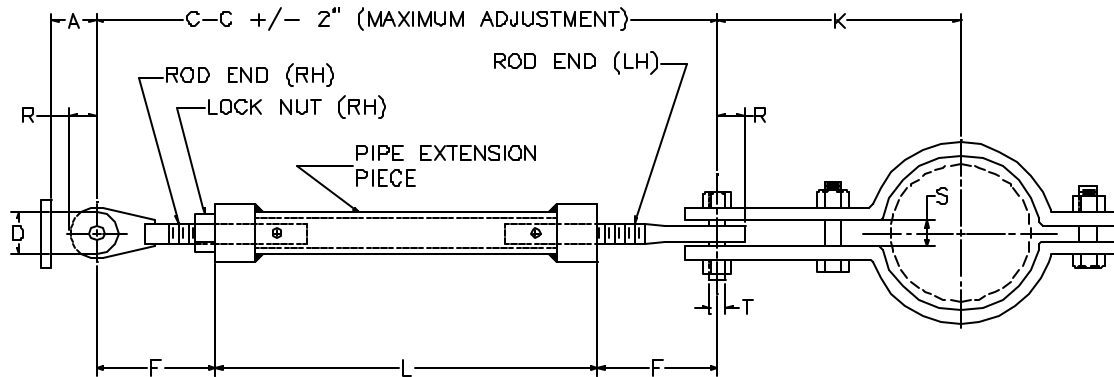

NOTE: See Fig. 325 for applicable K dimension.

SWAY STRUT SIZE	MAX. RATED TENSION LOAD (LBS)	ROD END			REAR BRACKET				NOM. PIN/STUD DIA. (IN)	EXTENSION PIECE			C - C	
		ROD END DIA. (IN)	PADDLE RADIUS (IN)	F (IN)	TAKE OUT A (IN)	H (IN)	W (IN)	N (IN)		PIPE DIA. (IN)	LENGTH L MIN. (IN)	LENGTH L MAX. (IN)	MIN. (IN)	MAX. (IN)
A	650	3/4	5/8	2 11/16	1	2 7/8	1 1/4	1/4	0.374	1	6 3/4	54 5/8	12 1/8	60
B	1500	1	1 3/8	3 11/16	2 1/8	5	3 5/8	1/2	0.749	1 1/2	7 1/16	88 5/8	###	96
C	4500	1	1 3/8	3 11/16	2 1/8	5	3 5/8	1/2	0.749	2	7 1/16	88 5/8	###	96
1	8000	1 1/4	1 1/2	4 1/8	2 1/2	4 1/2	3	3/4	0.999	2	8 1/4	87 3/4	16 1/2	96
2	11630	1 1/2	1 1/2	4 1/4	2 1/2	4 1/2	3	3/4	0.999	2 1/2	8 3/8	87 1/2	16 7/8	96
3	15700	1 3/4	2	5	3 1/4	5 3/8	3 9/16	1	1.249	2 1/2	8 3/8	86	18 3/8	96
4	20700	2	2	5 1/4	3 1/4	5 3/8	3 9/16	1	1.249	3	10	85 1/2	20 1/2	96
5	27200	2 1/4	2 1/2	6	4	6 1/8	4 1/4	1 1/4	1.499	3	10	84	22	96
6	33500	2 1/2	3	6 7/8	5	7 7/8	5 3/8	1 3/4	1.749	4	10	82 1/4	23 3/4	96
7	68200	3	3 1/2	8	5 3/4	9 1/8	6 1/4	2	1.999	4	12	80	28	96
8	120000	4	4 3/4	10 1/4	7 1/4	14	8 3/4	2 1/4	2.499	6	14 1/4	75 1/2	34 3/4	96