

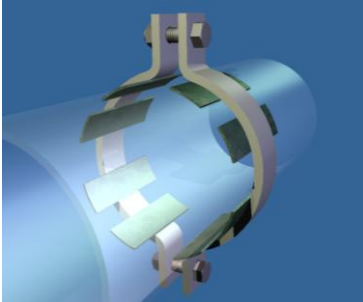

CORROSION PROTECTION PRODUCTS

TRI•WEAR™ Pads



TRI•WEAR™ pads are pipe protective coverings used to prevent corrosion and electrical conductivity between the pipe and the pipe support. They also prevent metal to metal abrasion & dampen vibrations. TRI•WEAR™ acts as a second skin reinforcing the contact surface. These pads are seal bonded to the pipe in order



to prevent moisture collection behind the wear pads. Bonded TRI•WEAR pads provide up to 45,000 psi compressive strength and work from -60°F to 500°F. They are available in pipe sizes from ¾" to 36".

TRI•COMPOSITE™ Pipe Shoes - (No Hot Permits required!)

These shoes are easy to install and greatly reduce the "Installed Cost" per shoe. They can be epoxied to the pipe or banded as shown. Made from high density polyurethane foam cores (cut by numerical control equipment) with a toughened FRP outer shell, the shoe has enhanced thermal insulating properties while preventing electrical conductivity and corrosion and can be used for pipes from -350°F up to 225°F. Our TRI•COMPOSITE Pipe Supports are available in light and heavy duty, strapped or bonded in pipe diameters of ¾" to 36".

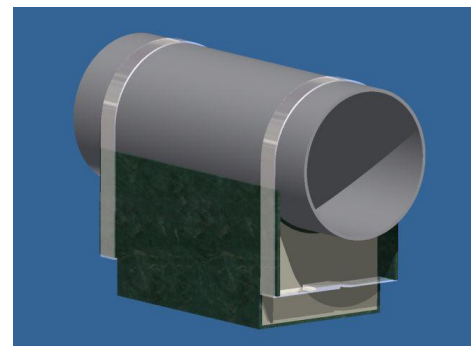

TRI•GUARD™ Durable Thermoplastic Supports

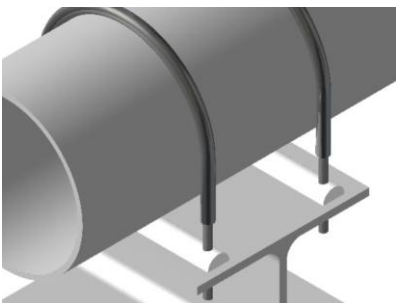

Corrosion between pipe supports and pipe at metal to metal contact points is a common problem in the process industry. TRI•GUARD™ thermoplastic bars placed under the pipe and around u-bolts, when lateral pipe restraint is required, eliminate most metal to metal contact and therefore the resultant corrosion. With TRI•GUARD™, water no longer pools on pipe support surfaces under the pipe. Water runs off due to the

TRI•GUARD™ shape. TRI•GUARD™ prevents electrical conductivity between the pipe and the pipe support member. TRI•GUARD™ can be used at operating temperatures up to 250°F (120°C) and under all pipe diameters up to 48". TRI•GUARD™ are available for higher temperature applications, however corrosion is generally not an issue on higher temperature piping systems. See our TRI•BOLT™ product line for coated U-bolts to be used with TRI•GUARD™ supports when lateral restraint is required.

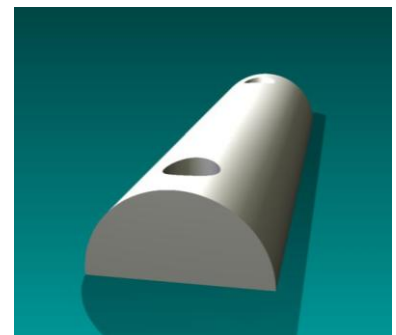



TRI•BOLT™ with UV Resistant Neoprene Coating

TRI•BOLT™ Neoprene Coated U-bolts provide the solution to corrosion resulting from metal to metal contact and provide cathodic protection for your pipe support applications. U-bolts of any grade carbon steel with a painted or galvanized finish or 304/316 stainless steel can be supplied. Long tangent and specialty sizes are available as well. Coatings are ideal for FRP and GRE piping applications and have rubber grommets.



VIBRATION CONTROL RESTRAINTS



Vibration Control Restraints are utilized extensively throughout the gas compression industry to reduce structural borne vibration and noise levels, to distribute loading on the surface of the pipe and thereby minimize localized stress concentrations, to provide corrosion and cathodic protection and to facilitate pipe movement resulting from thermal expansion and contraction. Elastomeric bearing pads are securely bonded to the appropriate contact surfaces to provide the corrosion protection while damping the piping vibrations. The hold down clamps handle temperatures from -65°F (-18°C) to 350°F (177°C). Clamps are available in Light Duty,

Standard Duty, Heavy Duty and Extra Heavy Duty. Innovative alternate “hold down clamp” designs as well as Wedge Blocks for use on compressor bottles are also available. All vibration control restraints are available for pipe diameters from ½” to 60”.

CORROSION PREVENTATIVE METHODS FOR PIPE CLAMPS & STANDS

Corrosion preventative metal surface dividers offered by AAA Technology include the following: Neoprene rubber, Elastomeric Bearing, PTFE (Glass Filled Teflon), Polyethylene Bearings, Thermoplastic Pads and Fiberglass Pads. Note that the PTFE and the Polyethylene Bearings provide a low friction sliding surface. Given your unique requirements for corrosion prevention as well as sliding support surfaces, we can engineer specific solutions for your requirements.

